

*Instruction Book For
Contour Electrol*

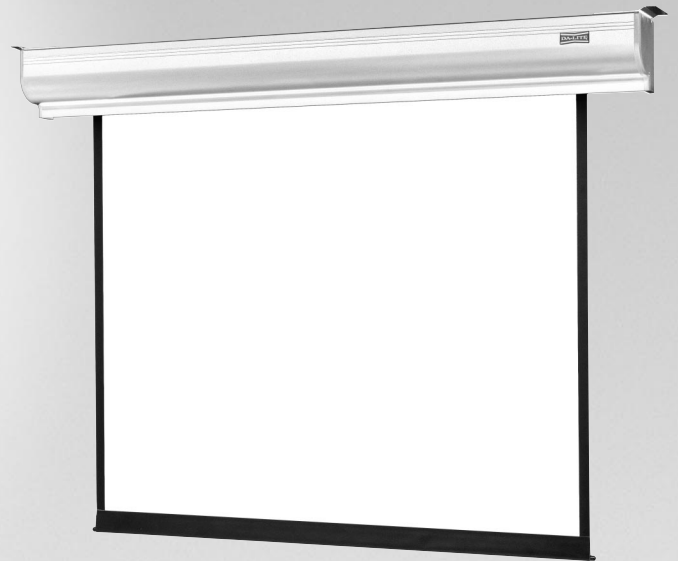

The
POWER *In*
PRESENTATION PRODUCTS



DA-LITE SCREEN COMPANY, INC.

3100 North Detroit Street
Post Office Box 137
Warsaw, Indiana 46581-0137
Phone: 574/267-8101
800-622-3737
Fax: 574/267-7804
[http:// www.da-lite.com](http://www.da-lite.com)
e-mail: info@da-lite.com

IMPORTANT SAFETY INSTRUCTIONS

When using your video equipment, basic safety precautions should always be followed, including the following:

1. Read and understand all instructions before using.
2. Position the cord so that it will not be tripped over, pulled, or contact hot surfaces.
3. If an extension cord is necessary, a cord with a current rating at least equal to that of the appliance should be used. Cords rated for less amperage than the appliance may overheat.
4. To reduce the risk of electric shock, do not disassemble this appliance. Contact an authorized service dealer when repair work is required. Incorrect reassembly can cause electric shock when the appliance is used subsequently.
5. The use of an accessory attachment not recommended by the manufacturer may cause a risk of fire, electric shock, or injury to persons.

SAVE THESE INSTRUCTIONS

INSTALLATION

Carefully unpack screen and remove outer wrapping from case.

Remove the black tape from the slat bar after the case has been installed.

There are three ways to install the Contour Electrol: Wall Mount, Ceiling Mount, or Ceiling Hook. Procedures for each method are as follows:

Wall Mount

1. Secure the wall mount brackets to the wall at the desired height. Brackets should be fastened to wall studs or some reinforcement within the wall. Concrete or brick walls require special fasteners and anchors.
2. Make sure the brackets are in line and level. See figure 1 for reference dimensions.
3. Keep in mind you will need at least 2-3/8" between the ceiling and the top of the wall mount bracket to be able to position the case on the bracket.
4. Mount the screen case on the wall bracket as shown in figure 1. Be sure the case is fully seated on the bracket. Tighten the stop screws against the wall brackets.

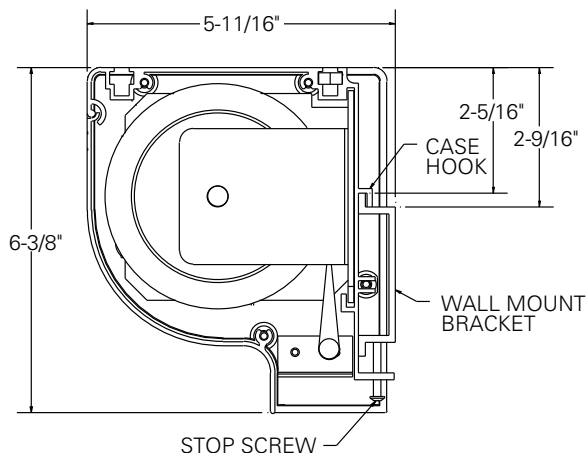

FIGURE 1

Ceiling Mount

1. Be sure the ceiling has adequate reinforcement to attach the screen brackets.
2. The top of the screen case has two channels with threaded nuts that slide the length of the case. Attach two ceiling mount brackets to the screen case as shown in figure 2.
3. Hold the screen case up to the ceiling and mark the hole locations. The brackets have a set of front holes and a set of rear holes. It is best to use at least one hole in each set.

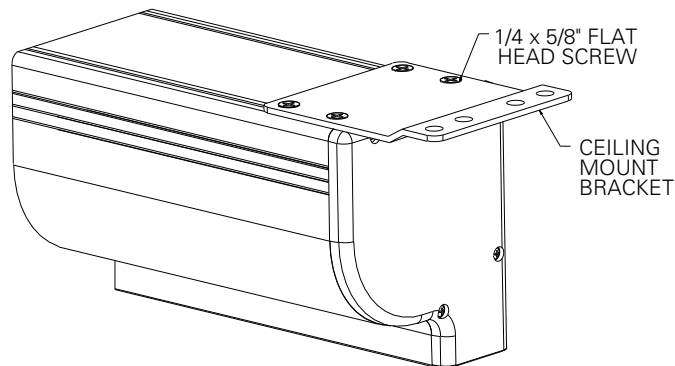

FIGURE 2

Ceiling Hook

1. Be sure the ceiling has adequate reinforcement to attach a hook anchor.
2. The top of the screen case has two channels with threaded nuts that slide the length of the case. Attach two or three ceiling hook brackets as provided to the screen case as shown in figure 3.
3. The brackets can be attached anywhere along the length of the case. If two brackets are provided, it's recommended to keep the brackets near the ends of the case. If three brackets are provided, it's recommended to attach one near the center of the case and the other two near the ends of the case.

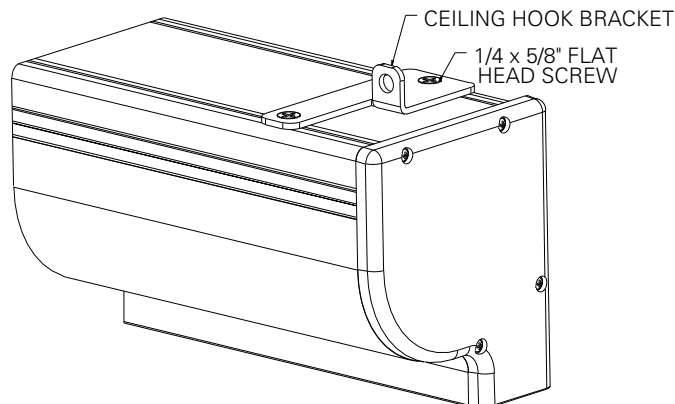

FIGURE 3

ROLLER ASSEMBLY INSTALLATION

If your roller assembly was shipped separate from the screen case follow the steps below for installation.

1. Remove the case cover screw from both ends of the screen. See figure 4. Be sure to hold the cover while removing the screws.
2. Rotate the cover up and away from the case until it can be removed. See figure 5.
3. Loosen the four set screws on the pin end bracket and slide it to the right end of the case.
4. Install the motor end first by inserting the square pin on the end of the motor into the motor bracket. The white and yellow limit screws on the motor should point to the front of the case.
5. Slide the pin end bracket onto the roller pin and tighten the four set screws in the bracket.

CAUTION: Make sure the motor pin is fully seated in the motor bracket before tightening the pin end set screws.

6. Plug the motor connector into the case connector.
7. Install the case cover. Procedure is reverse of removal.

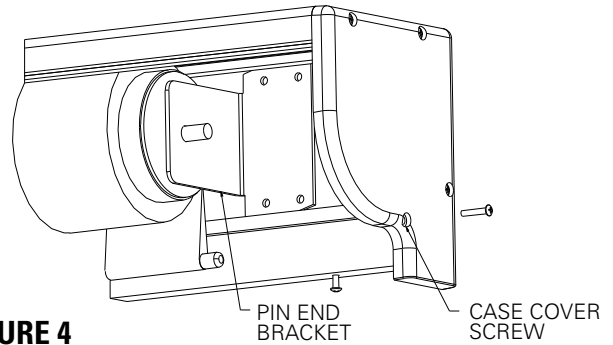

FIGURE 4

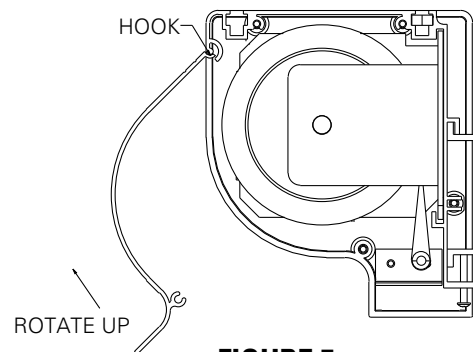

FIGURE 5

ELECTRICAL INSTALLATION

Internal wiring has been completed at the factory. Installer must route power to the wall switch and to the junction box located on the left end of the screen case.

Standard installation is for a single 120VAC or 240VAC wall switch to control the screen. Optional Control units may have been ordered, including a video projector interface or low voltage control unit. Refer to the appropriate wiring diagram for your screen.

SCREEN ADJUSTMENT

Screen travel is stopped automatically in the down and up positions by the limit switches that are preset at the factory. If it's necessary to adjust for more or less drop follow the steps below. The case cover must be removed to access the motor limit switches.

Remove the case cover screw from both ends of the screen. See figure 4. Be sure to hold the cover while removing the screws.

Rotate the cover up and away from the case until it can be removed.

SETTING THE DOWN LIMIT POSITION

TO REDUCE SCREEN DROP:

Turn the white limit switch screw clockwise to decrease the amount of screen drop. Run the screen down to test the stop position. If the screen drops too far, raise the screen about one foot and adjust the limit switch again. Repeat until the desired position is set.

TO INCREASE SCREEN DROP:

Turn the white limit switch screw counterclockwise to increase the amount of screen drop. Run the screen down to test the stop position. If the screen does not drop enough, raise the screen about one foot and adjust the limit switch again. Repeat until the desired position is set. Do not adjust for more drop than what was ordered. At least 1-1/2 wraps of fabric must remain on the roller.

SETTING THE UP LIMIT POSITION

CAUTION: Do not allow the slat bar to wrap over the top of the roller when the screen is rolling into the case. The screen could be damaged.

SCREEN TRAVELS INTO CASE TOO FAR:

Turn the yellow limit switch screw clockwise to decrease the amount of travel. Run the screen up to test the stop position. If the screen does not stop properly, lower the screen about one foot and turn the limit switch again. Repeat until the desired position is set.

SCREEN DOES NOT TRAVEL FAR ENOUGH INTO CASE:

Turn the yellow limit switch screw counterclockwise to increase the amount of up travel. Run the screen up to test the stop position. If more travel is desired, lower the screen about one foot and adjust the limit switch again. Repeat until the desired position is set.

CONTOUR ELECTROL INSTALLATION

120V WIRING DIAGRAM FOR STANDARD WALL SWITCH

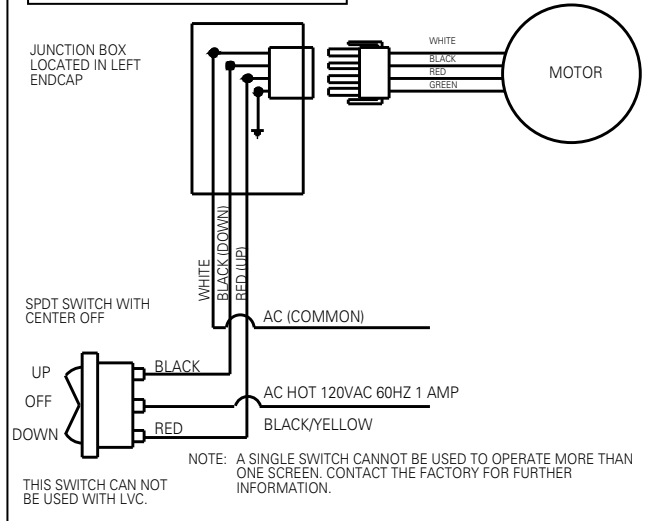

240V WIRING DIAGRAM FOR STANDARD WALL SWITCH

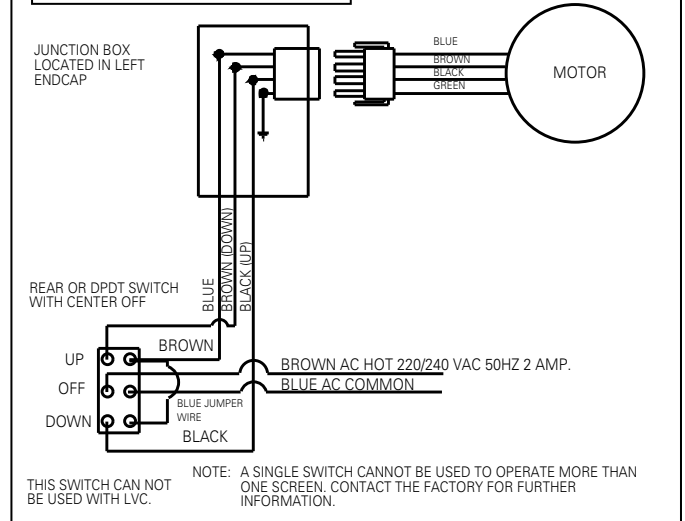

120V WIRING DIAGRAM WITH OPTIONAL BUILT-IN VIDEO PROJECTOR INTERFACE

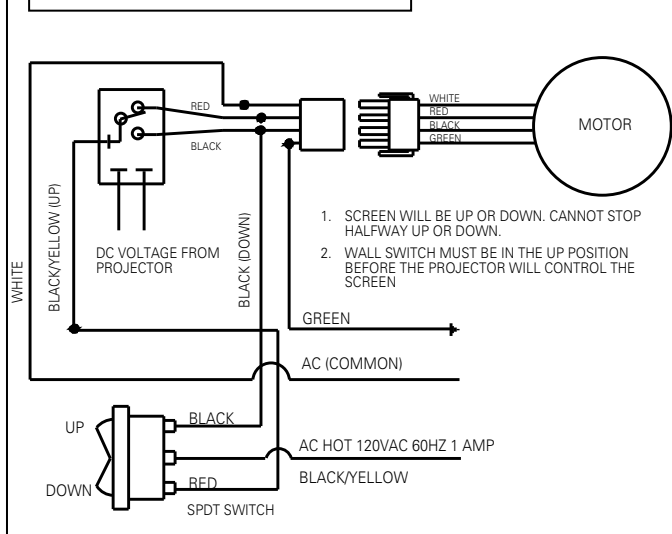

240V WIRING DIAGRAM WITH OPTIONAL BUILT-IN VIDEO PROJECTOR INTERFACE

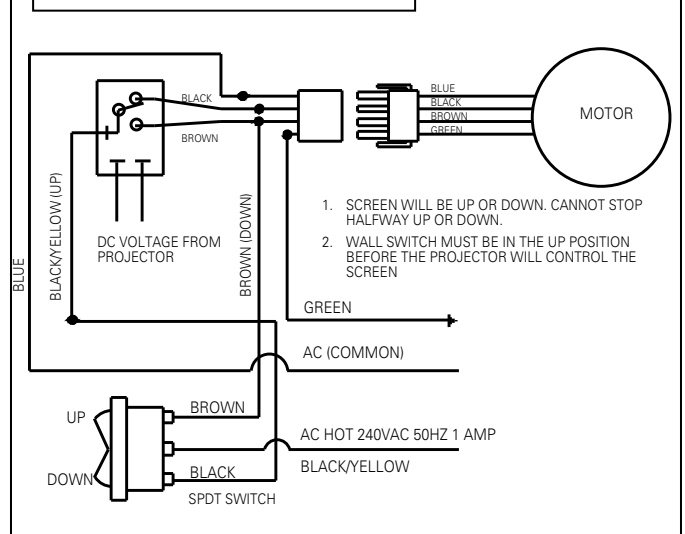

CONTOUR ELECTROL INSTALLATION

120V WIRING DIAGRAM WITH OPTIONAL BUILT-IN LOW VOLTAGE CONTROL

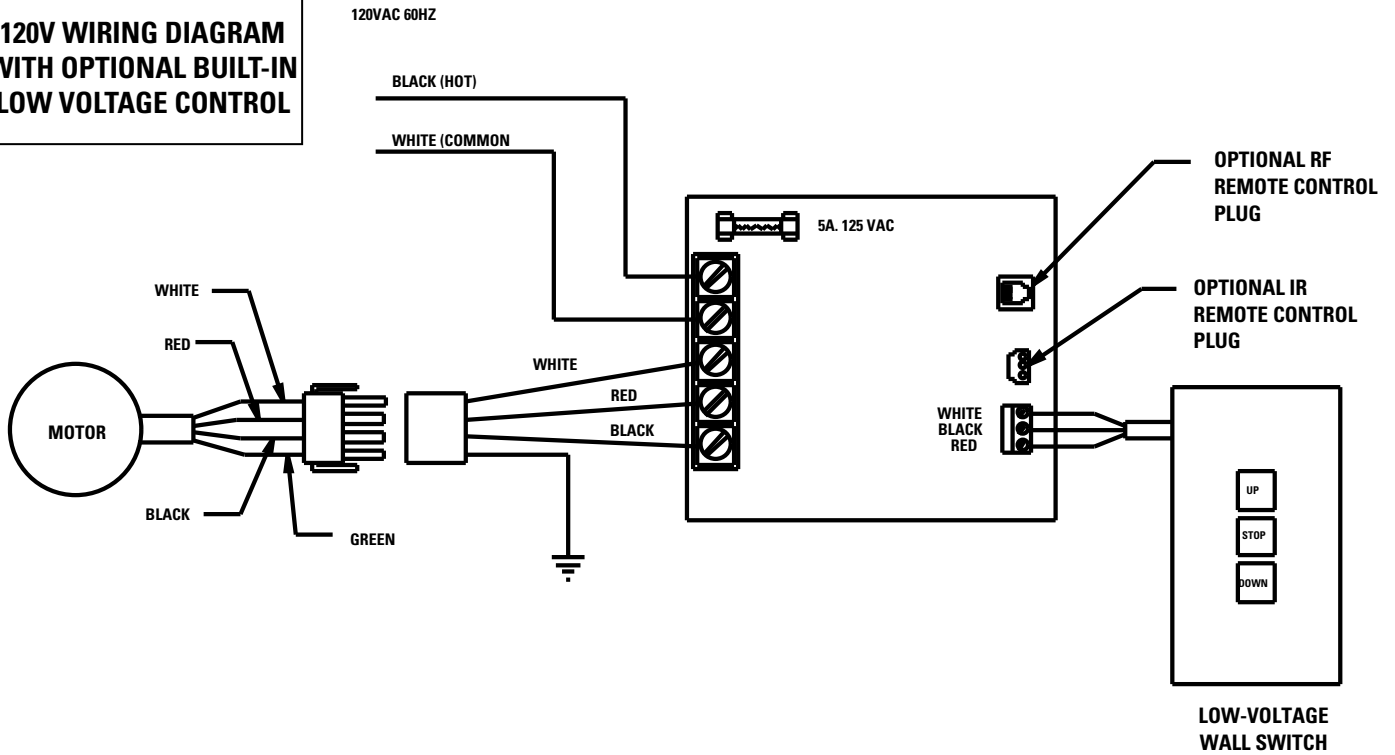

FIGURE 10

240V WIRING DIAGRAM WITH OPTIONAL BUILT-IN LOW VOLTAGE CONTROL

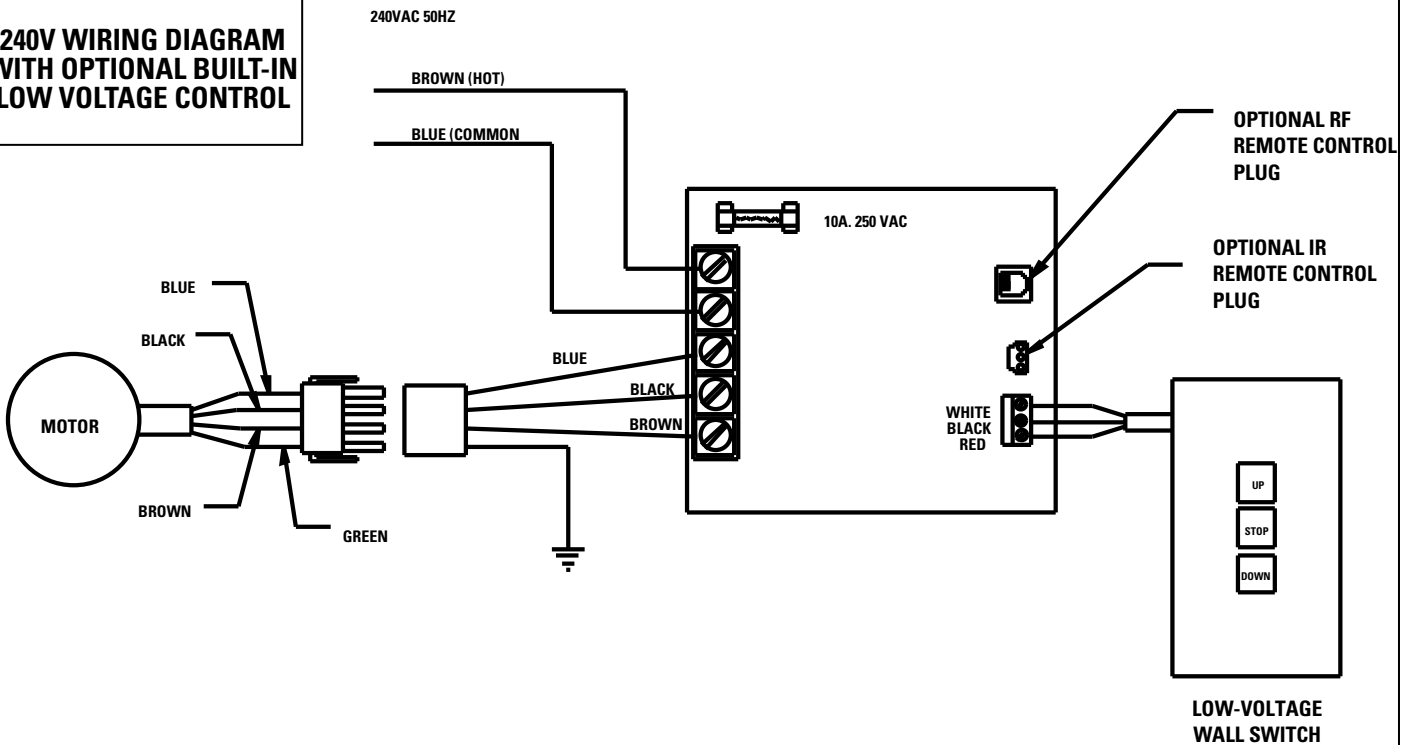

FIGURE 11

TROUBLESHOOTING

SYMPTOM	CAUSE	SOLUTION
1. Screen will not operate. Motor does not hum.	(a) Blown fuse. (b) Tripped circuit breaker. (c) No power to operating switch or junction. Power at junction box (d) Thermal overload tripped. (e) Broken wire in the "down" or "up" position. (f) Defective motor, limit switch or capacitor. (g) Capacitor burned out.	(a) Replace fuse. (b) Reset circuit breaker. (c) Check above. Tighten all loose wire connections. Correct any improper connections. "Down" Position Check for power across black and white leads. "Up" Position Check for power across red and white leads. (d) Let motor cool down for 15 minutes. Try again. (e) Check for continuity. Cut off old splice and reconnect. (f) Replace motor assembly. NOTE: Motor is a sealed assembly. (g) Replace motor assembly.
2. Incorrect stopping position in downward direction.	(a) Lost roller wrap. (b) "Down" limit switch out of adjustment	(a) See instructions below. (b) See installation instructions.
3. Incorrect stopping position in upward direction.	(a) Lost roller wrap. (b) "Up" limit switch out of adjustment	(a) See instructions below. (b) Adjust "up" limit switch. See installation instructions
4. Noise. NOTE: Screen will operate with a low pitched hum.	(a) Gear Noise.	(a) Replace motor assembly.
5. Coasting.	(a) Defective brake.	(a) Replace motor assembly.

RESTORING LOST ROLLER WRAP

1. Tape a strap to the bottom of the screen surface.
2. Push strap over back of roller.
3. Feed fabric as you pull strap to draw fabric over top of roller.
4. Remove tape and strap.

LIMITED ONE YEAR WARRANTY ON DA-LITE PROJECTION SCREENS

Da-Lite Screen Company, Inc. warrants its screens to the original purchaser only, to be free from defects in materials and workmanship for a period of one (1) year from the date of purchase by the original purchaser provided they are properly operated according to Da-Lite's instructions and are not damaged due to improper handling or treatment after shipment from the factory.

This warranty does not apply to equipment showing evidence of misuse, abuse, or accidental damage, or which has been tampered with or repaired by person other than authorized Da-Lite personnel.

Da-Lite's sole obligation under this warranty shall be to repair or to replace (at Da-Lite's option) the defective part of the merchandise. Returns for service should be made to your Da-Lite dealer. If it is necessary for the dealer to return the screen or part to Da-Lite, transportation expenses to and from Da-Lite are payable by the purchaser and Da-Lite is not responsible for damage in shipment. To protect yourself against damage or loss in transit, insure the product and prepay all transportation expenses.

THIS WARRANTY IS IN LIEU OF ALL OTHER WARRANTIES, EXPRESS OR IMPLIED, INCLUDING WARRANTIES AS TO FITNESS FOR USE AND MERCHANTABILITY. Any implied warranties of fitness for use, or merchantability, that may be mandated by statute or rule of law are limited to the one (1) year warranty period. This warranty gives you specific legal rights, and you may also have other rights which vary from state-to-state. NO LIABILITY IS ASSUMED FOR EXPENSES OR DAMAGES RESULTING FROM INTERRUPTION IN OPERATION OF EQUIPMENT, OR FOR INCIDENTAL, DIRECT, OR CONSEQUENTIAL DAMAGES OF ANY NATURE.

In the event that there is a defect in materials or workmanship of a Da-Lite Screen, you may contact our Customer Service Department at P.O. Box 137, Warsaw, Indiana 46581-0137 (574/267-8101) Toll Free (800/622-3737).

IMPORTANT: THIS WARRANTY SHALL NOT BE VALID AND DA-LITE SHALL NOT BE BOUND BY THIS WARRANTY IF THE PRODUCT IS NOT OPERATED IN ACCORDANCE WITH DA-LITE'S WRITTEN INSTRUCTIONS.

Keep your sales receipt to prove the date of purchase and your original ownership.