

Instruction Book For
Designer Contour Electrol



The
POWER *In*
PRESENTATION PRODUCTS



DA-LITE SCREEN COMPANY, INC.

3100 North Detroit Street
Post Office Box 137
Warsaw, Indiana 46581-0137
Phone: 574/267-8101
800-622-3737
Fax: 574/267-7804
[http:// www.da-lite.com](http://www.da-lite.com)
e-mail: info@da-lite.com

IMPORTANT SAFETY INSTRUCTIONS

When using your video equipment, basic safety precautions should always be followed, including the following:

1. Read and understand all instructions before using.
2. Position the cord so that it will not be tripped over, pulled, or contact hot surfaces.
3. If an extension cord is necessary, a cord with a current rating at least equal to that of the appliance should be used. Cords rated for less amperage than the appliance may overheat.
4. To reduce the risk of electric shock, do not disassemble this appliance. Contact an authorized service dealer when repair work is required. Incorrect reassembly can cause electric shock when the appliance is used subsequently.
5. The use of an accessory attachment not recommended by the manufacturer may cause a risk of fire, electric shock, or injury to persons.

SAVE THESE INSTRUCTIONS

INSTALLATION

Carefully unpack screen and remove outer wrapping from case.

Remove the black tape from the slat bar after the case has been installed.

There are three ways to install the Designer Contour Electrol: Wall Mount, Ceiling Mount, or Ceiling Hook. Procedures for each method are as follows:

Wall Mount

1. Secure the wall mount brackets to the wall at the desired height. Brackets should be fastened to wall studs or some reinforcement within the wall. Concrete or brick walls require special fasteners and anchors.
2. Make sure the brackets are in line and level. See figure 1 for reference dimensions.
3. Keep in mind you will need at least 5/8" between the ceiling and the top of the wall mount bracket to be able to position the case on the bracket.
4. Mount the screen case on the wall bracket as shown in figure 1. Be sure the case is fully seated on the bracket. Tighten the stop screws against the wall brackets.

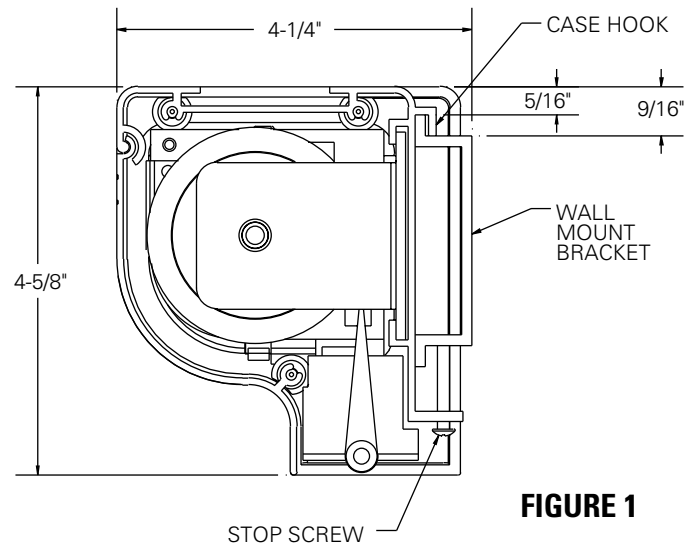

FIGURE 1

Ceiling Mount

1. Be sure the ceiling has adequate reinforcement to attach the screen brackets.
2. The top of the screen case has a channel that the ceiling mount brackets slide into. Remove the end cap on the right end of the case and insert the brackets into the case channel. Lock the brackets in place by tightening two set screws. Refer to figure 2.
3. Hold the screen case up to the ceiling and mark the hole locations. Drill holes into the ceiling and attach screen with the appropriate fasteners for your ceiling.

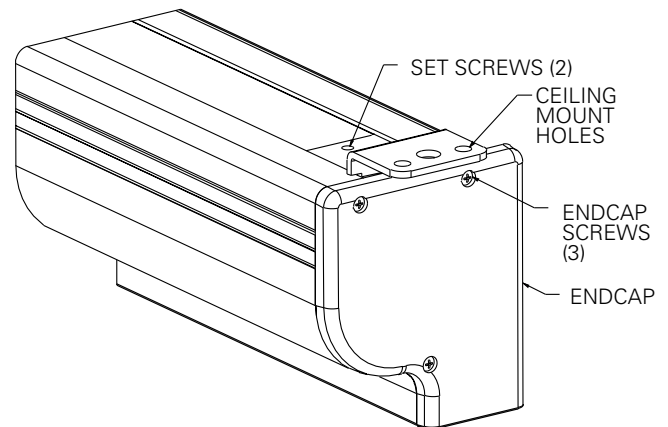

FIGURE 2

Ceiling Hook

1. Be sure the ceiling has adequate reinforcement to attach a hook anchor.
2. The top of the screen case has a channel that the ceiling hook brackets slide into. Remove the end cap on the right end of the case and insert the brackets into the case channel. Lock the brackets in place by tightening two set screws. Refer to figure 3.
3. The brackets can be attached anywhere along the length of the case.
4. Attach an S-hook to the large center hole on the bracket.

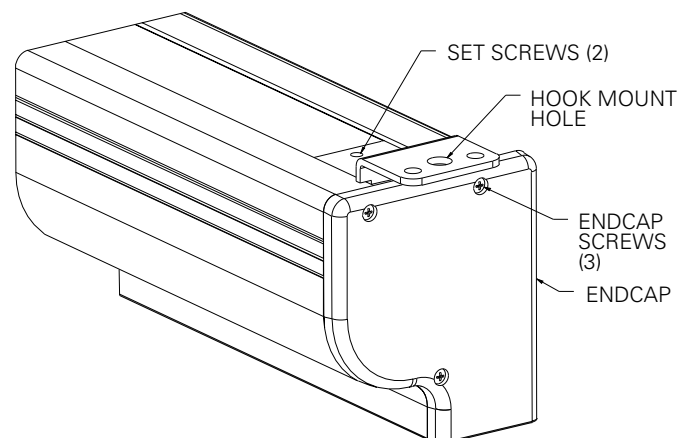
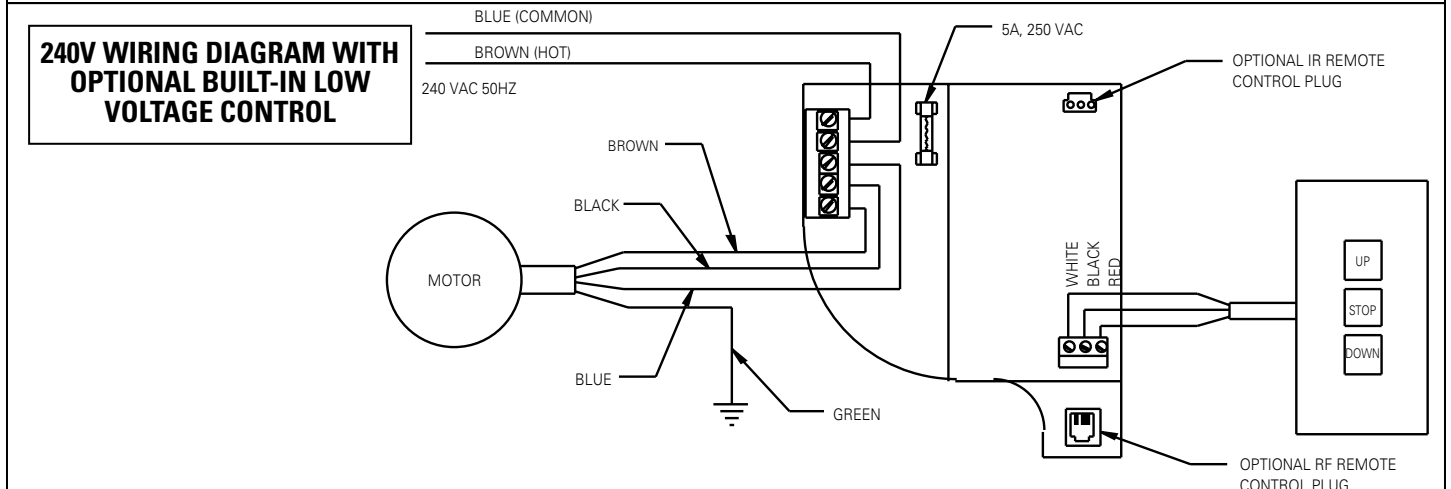
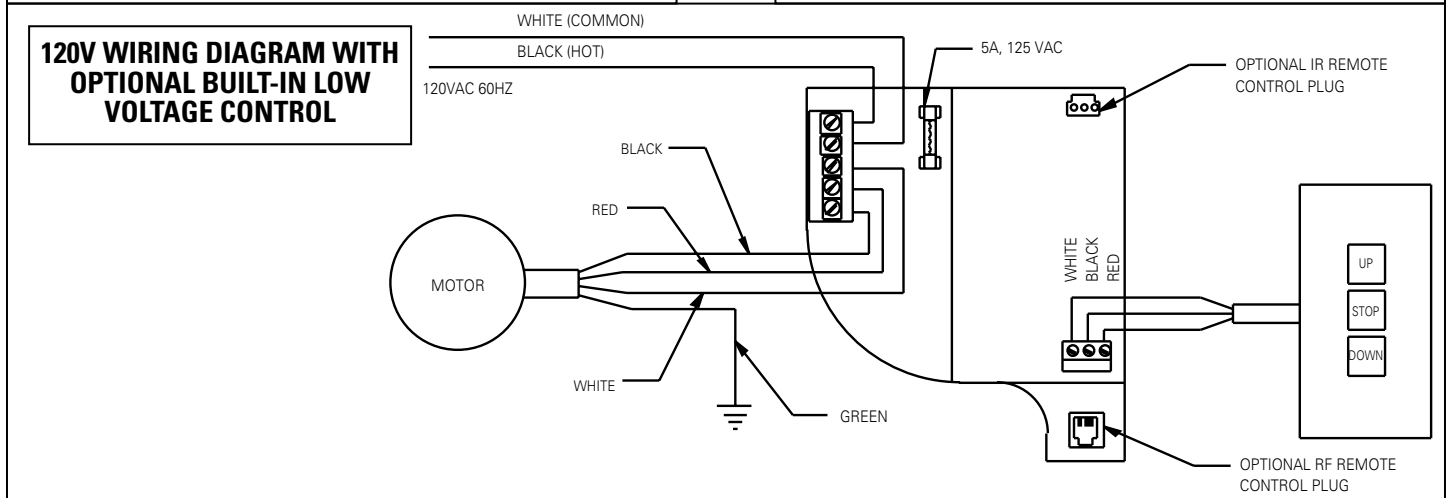
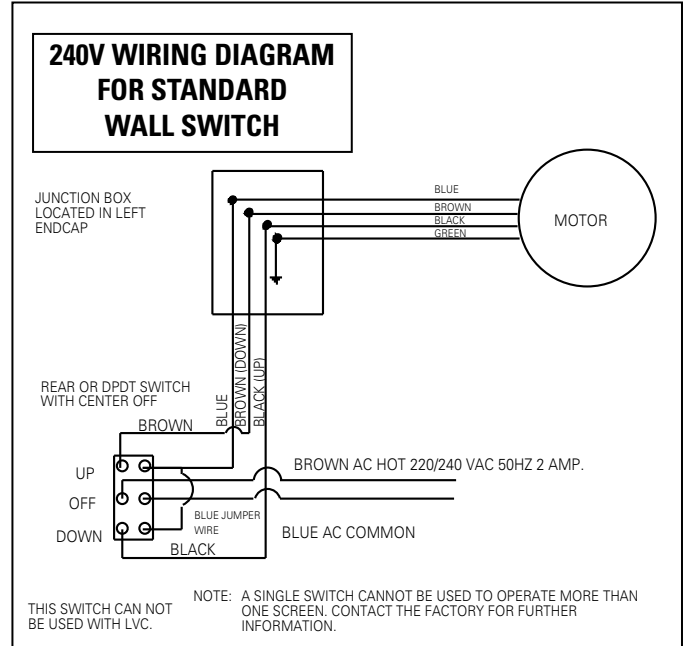
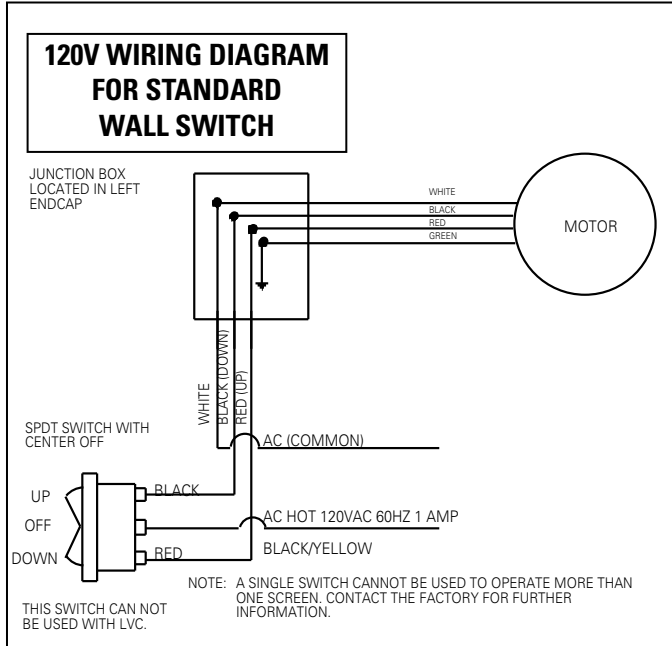

FIGURE 3

ELECTRICAL INSTALLATION

Internal wiring has been completed at the factory. Installer must route power to the wall switch and to the junction box located on the left end of the screen case.

Standard installation is for a single 120VAC or 240VAC wall switch to control the screen. Optional Control units may have been ordered, including a low voltage control unit. Refer to the appropriate wiring diagram for your screen.



SCREEN ADJUSTMENT

Screen travel is stopped automatically in the down and up positions by the limit switches that are preset at the factory. If it's necessary to adjust for more or less drop follow the steps below. Adjustment procedures are different for 120V and 240V units. Follow the appropriate instructions for your screen type. The case cover must be removed to access the motor limit switches.

Remove the case cover screw from both ends of the screen. See figure 4. Be sure to hold the cover while removing the screws.

Rotate the cover up and away from the case until it can be removed.

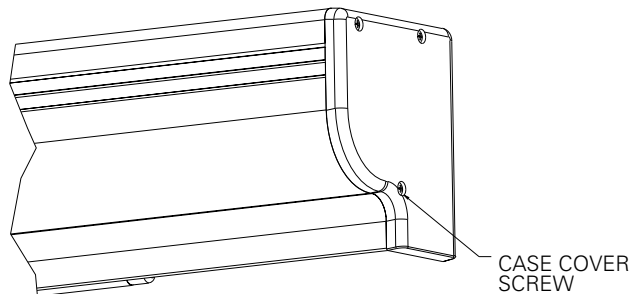

FIGURE 4

INSTRUCTIONS FOR 120 VOLT SCREENS

SETTING THE DOWN LIMIT POSITION

TO REDUCE SCREEN DROP:

Turn the number 1 limit switch screw clockwise to decrease the amount of screen drop. Run the screen down to test the stop position. If the screen drops too far, raise the screen about one foot and adjust the limit switch again. Repeat until the desired position is set.

TO INCREASE SCREEN DROP:

Turn the number 1 limit switch screw counterclockwise to increase the amount of screen drop. Run the screen down to test the stop position. If the screen does not drop enough, raise the screen about one foot and adjust the limit switch again. Repeat until the desired position is set. Do not adjust for more drop than what was ordered. At least 1-1/2 wraps of fabric must remain on the roller.

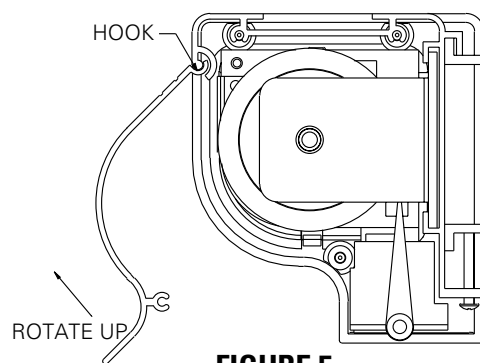

FIGURE 5

SETTING THE UP LIMIT POSITION



CAUTION: Do not allow the slat bar to become wedged between the roller and case. This could damage the fabric and motor. Always check that the slat is free to move inside the case.

SCREEN TRAVELS INTO CASE TOO FAR:

Turn the number 2 limit switch screw clockwise to decrease the amount of travel. Run the screen up to test the stop position. If the screen does not stop properly, lower the screen about one foot and turn the limit switch again. Repeat until the desired position is set.

SCREEN DOES NOT TRAVEL FAR ENOUGH INTO CASE:

Turn the number 2 limit switch screw counterclockwise to increase the amount of up travel. Run the screen up to test the stop position. If more travel is desired, lower the screen about one foot and adjust the limit switch again. Repeat until the desired position is set.

SCREEN ADJUSTMENT

INSTRUCTIONS FOR 240 VOLT SCREENS

SETTING THE DOWN LIMIT POSITION

TO REDUCE SCREEN DROP:

Turn the ⬆️ limit switch screw counterclockwise to decrease the amount of screen drop. Run the screen down to test the stop position. If the screen drops too far, raise the screen about one foot and adjust the limit switch again. Repeat until the desired position is set.

TO INCREASE SCREEN DROP:

Turn the ⬆️ limit switch screw clockwise to increase the amount of screen drop. Run the screen down to test the stop position. If the screen does not drop enough, raise the screen about one foot and adjust the limit switch again. Repeat until the desired position is set. Do not adjust for more drop than what was ordered. At least 1-1/2 wraps of fabric must remain on the roller.

SETTING THE UP LIMIT POSITION



CAUTION: Do not allow the slat bar to become wedged between the roller and case. This could damage the fabric and motor. Always check that the slat is free to move inside the case.

SCREEN TRAVELS INTO CASE TOO FAR:

Turn the ⬆️ limit switch screw clockwise to decrease the amount of travel. Run the screen up to test the stop position. If the screen does not stop properly, lower the screen about one foot and turn the limit switch again. Repeat until the desired position is set.

SCREEN DOES NOT TRAVEL FAR ENOUGH INTO CASE:

Turn the ⬆️ limit switch screw counterclockwise to increase the amount of up travel. Run the screen up to test the stop position. If more travel is desired, lower the screen about one foot and adjust the limit switch again. Repeat until the desired position is set.

TROUBLESHOOTING

SYMPTOM	CAUSE	SOLUTION
1. Screen will not operate. Motor does not hum.	(a) Blown fuse. (b) Tripped circuit breaker. (c) No power to operating switch or junction. Power at junction box (d) Thermal overload tripped. (e) Broken wire in the "down" or "up" position. (f) Defective motor, limit switch or capacitor. (g) Capacitor burned out.	(a) Replace fuse. (b) Reset circuit breaker. (c) Check above. Tighten all loose wire connections. Correct any improper connections. "Down" Position Check for power across black and white leads. "Up" Position Check for power across red and white leads. (d) Let motor cool down for 15 minutes. Try again. (e) Check for continuity. Cut off old splice and reconnect. (f) Replace motor assembly. NOTE: Motor is a sealed assembly. (g) Replace motor assembly.
2. Incorrect stopping position in downward direction.	(a) Lost roller wrap. (b) "Down" limit switch out of adjustment	(a) See instructions below. (b) See installation instructions.
3. Incorrect stopping position in upward direction.	(a) Lost roller wrap. (b) "Up" limit switch out of adjustment	(a) See instructions below. (b) Adjust "up" limit switch. See installation instructions
4. Noise. NOTE: Screen will operate with a low pitched hum.	(a) Gear Noise.	(a) Replace motor assembly.
5. Coasting.	(a) Defective brake.	(a) Replace motor assembly.

RESTORING LOST ROLLER WRAP

1. Tape a strap to the bottom of the screen surface.
2. Push strap over back of roller.
3. Feed fabric as you pull strap to draw fabric over top of roller.
4. Remove tape and strap.

